



### AT A GLANCE:

- Rated Capacity — 16,000 pounds
- Vertical Reach — 28' 0"
- Horizontal Reach — 24' 0"
- Continuous Rotation
- 10' 2" Turning Radius with  
Optional Four Wheel Steer
- Carry Deck
- Hydraulic Outriggers

**DMC BRODERSON**  
Manufacturing Corp.

P.O. Box 14770, Lenexa, KS 66285-4770  
(913) 888-0606 • FAX (913) 541-0690

# IC-80

## IC-80-1D

8'2"-20'2" Boom

LOAD RADIUS FEET	3-SECTION BOOM		10' BOOM EXTENSION INSTALLED	
	ON O.R.*	ON RUBBER	ON O.R.*	ON RUBBER
5	16000	9500	7000	7000
6	14500	8500	6000	6000
8	10250	6000	5000	5000
10	7700	4150	4000	4000
12	6550	3100	3450	3275
14	5550	2425	3050	2650
16	4450	1975	2700	2175
18	3950	1625	2250	1850
20	3550	1400	2250	1550
22			2250	1325
24			2250	1200
26			2250	975
28			2150	825
30			1825	675

1. Capacities on outriggers are 85% of tipping loads. Capacities on rubber 75% of tipping loads.
2. Deduct 120 lbs. with Boom Extension in stowed position.

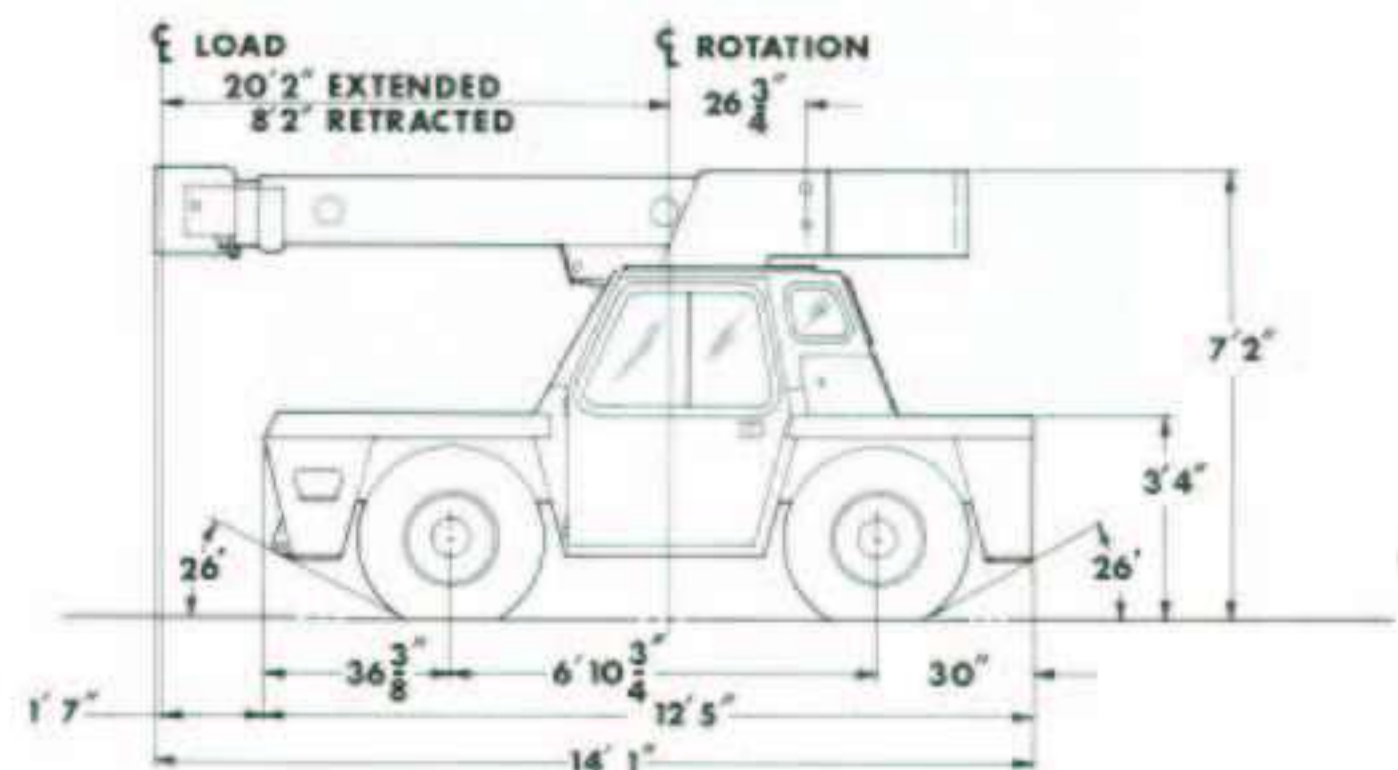
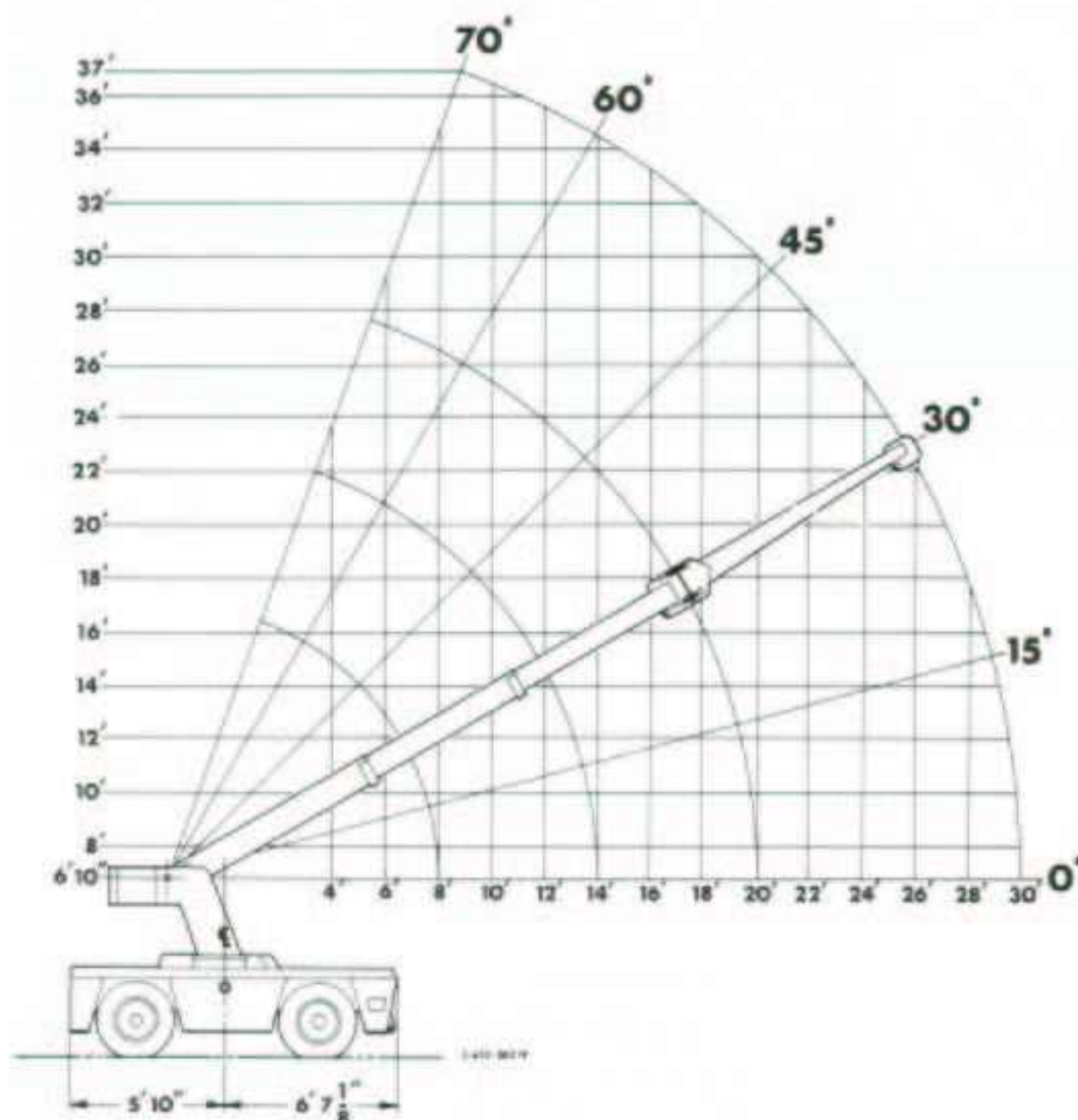
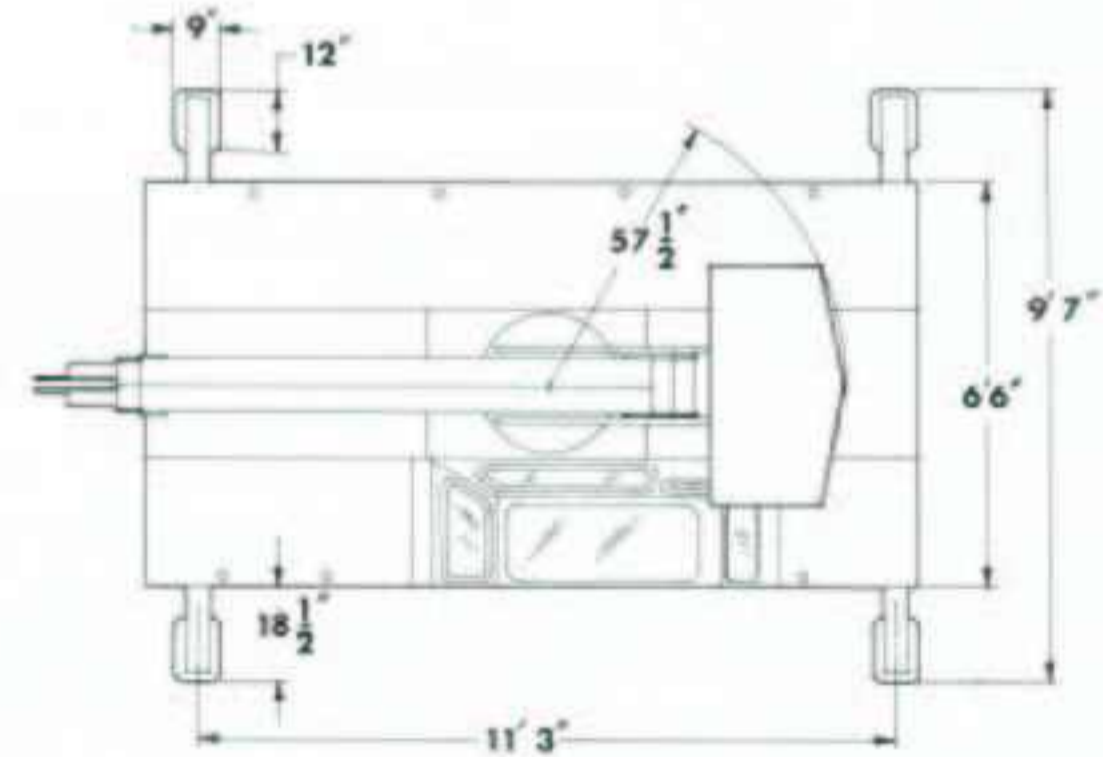
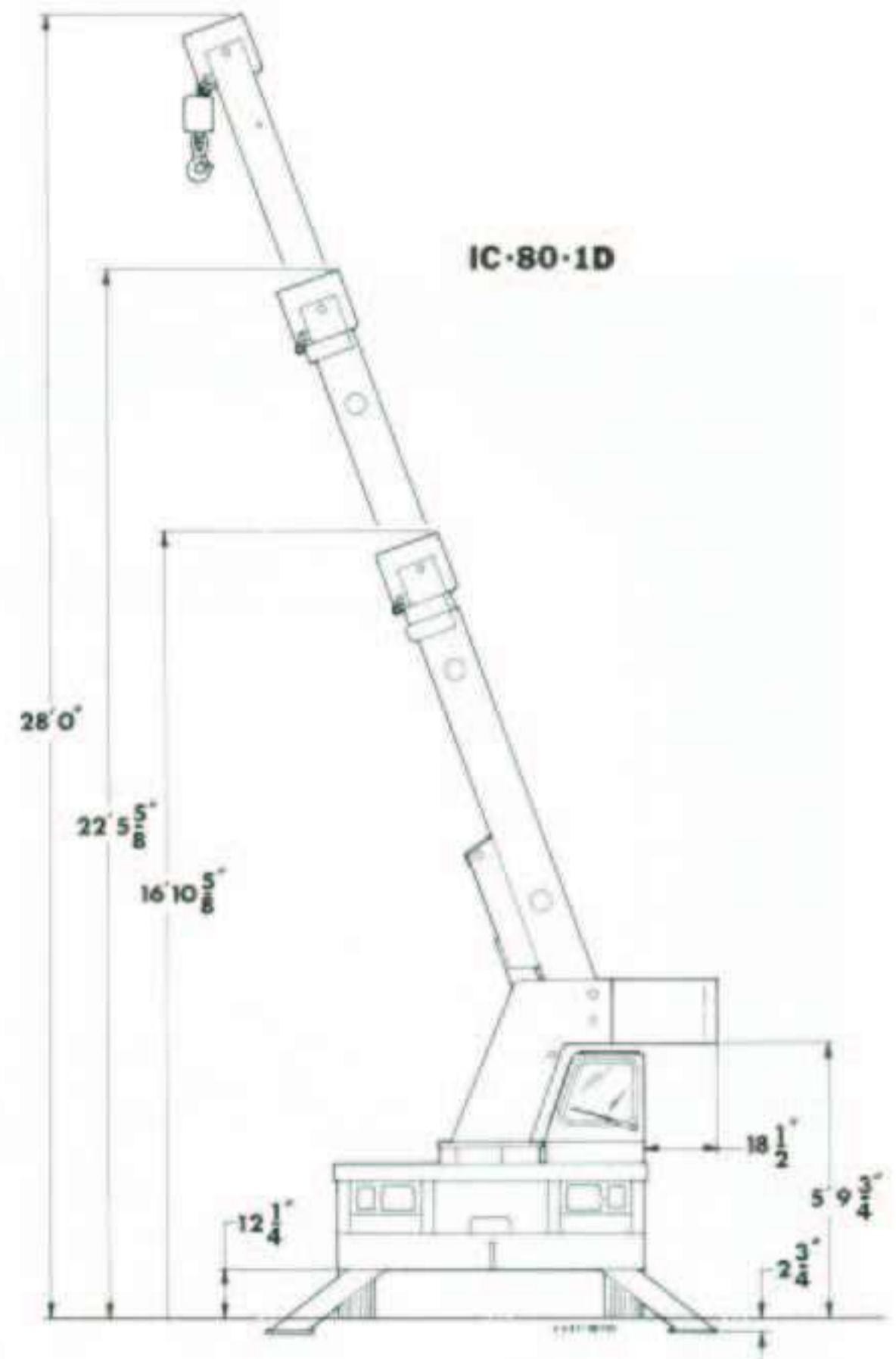
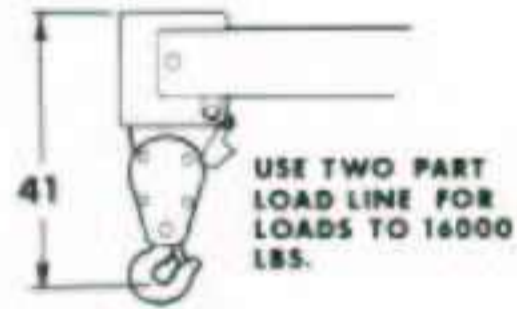

# IC-80

## IC-80-2D

9'6"-24'0" Boom

LOAD RADIUS FEET	3-SECTION BOOM		10' BOOM EXTENSION INSTALLED	
	ON O.R.*	ON RUBBER	ON O.R.*	ON RUBBER
5	16000	9500	7000	7000
6	14500	8500	6000	6000
8	10250	6000	5000	5000
10	7700	4150	4000	4000
12	6550	3025	3450	3275
14	5550	2350	3050	2600
16	4450	1850	2700	2125
18	3950	1550	2250	1800
20	3250	1300	2250	1525
22	2875	1100	2250	1275
24	2475	925	2250	1050
26			2250	850
28			2000	700
30			1775	600
32			1625	525
34			1400	450

1. Capacities on outriggers are 85% of tipping loads. Capacities on rubber 75% of tipping loads.

2. Deduct 120 lbs. with Boom Extension in stowed position.

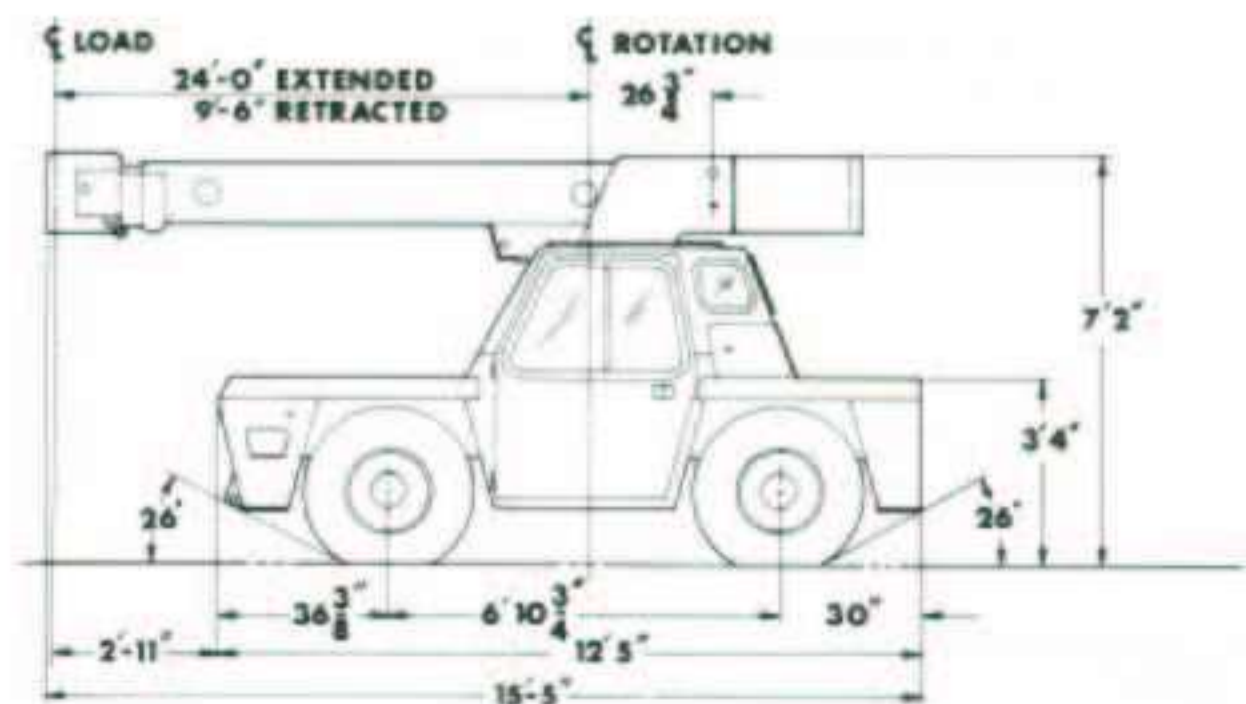
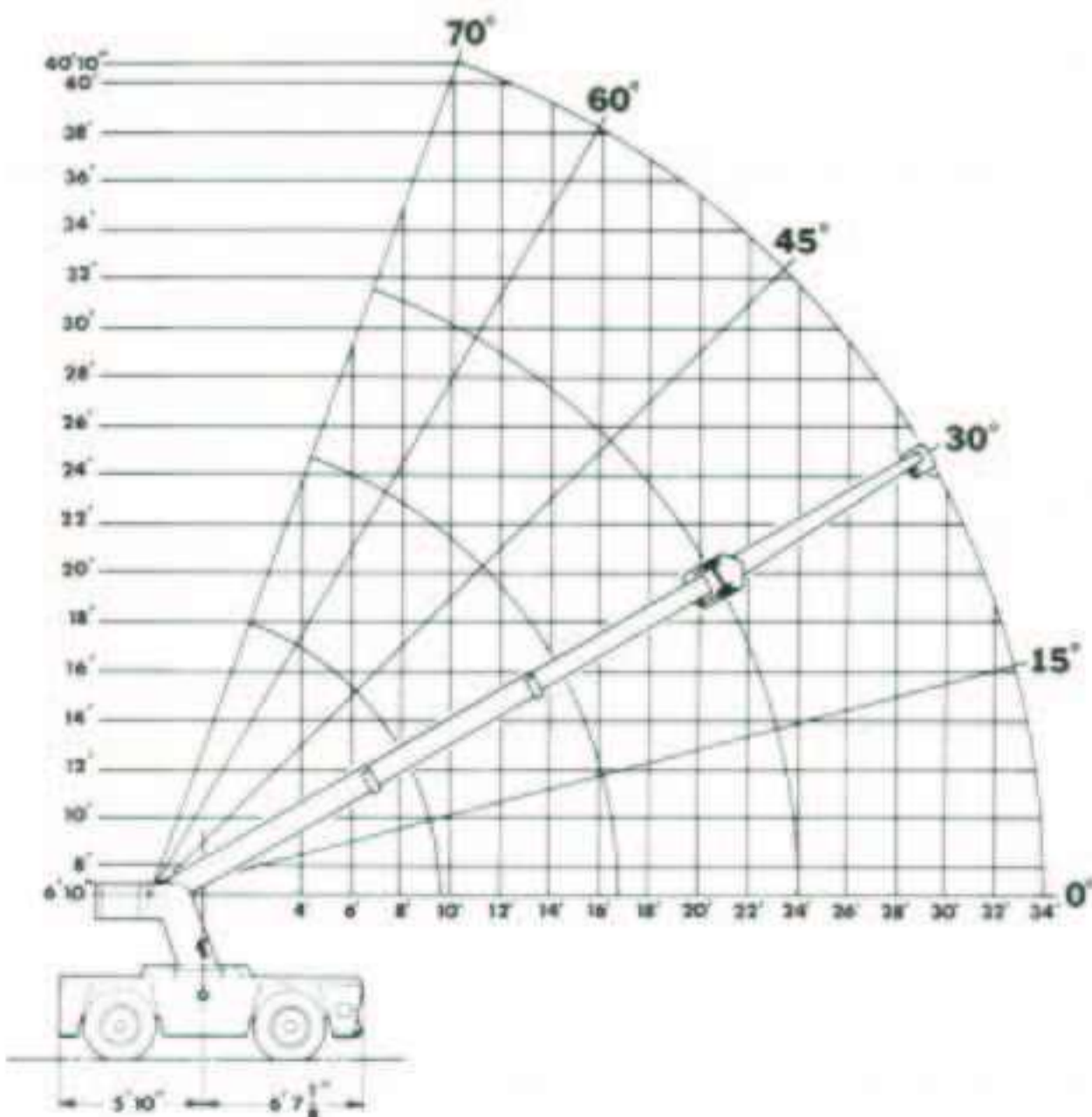
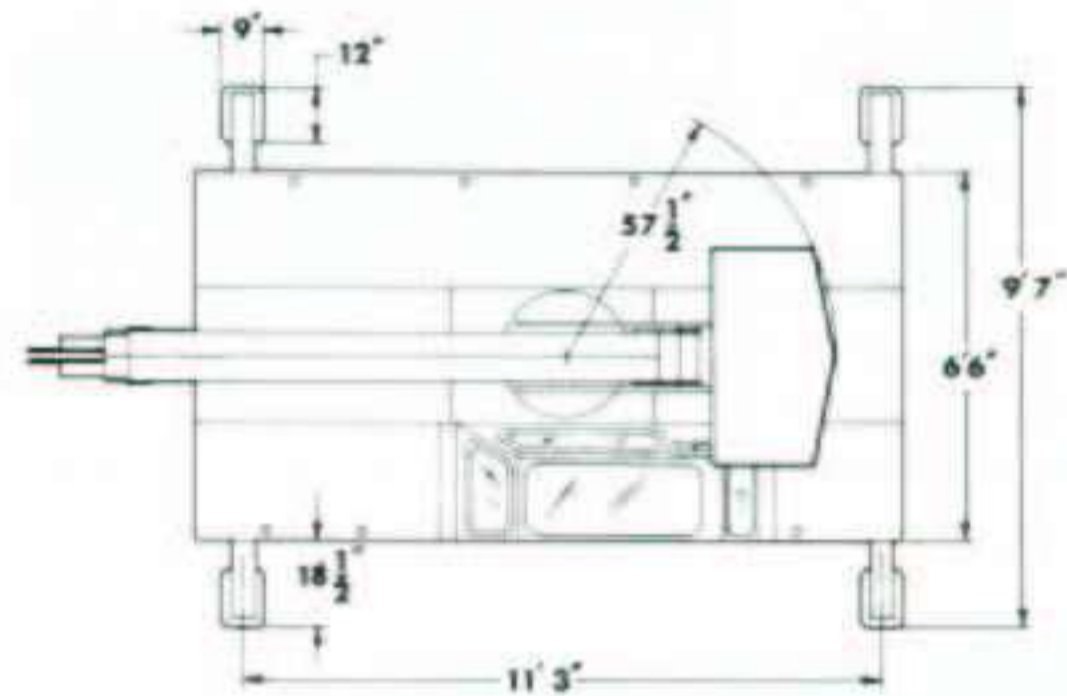
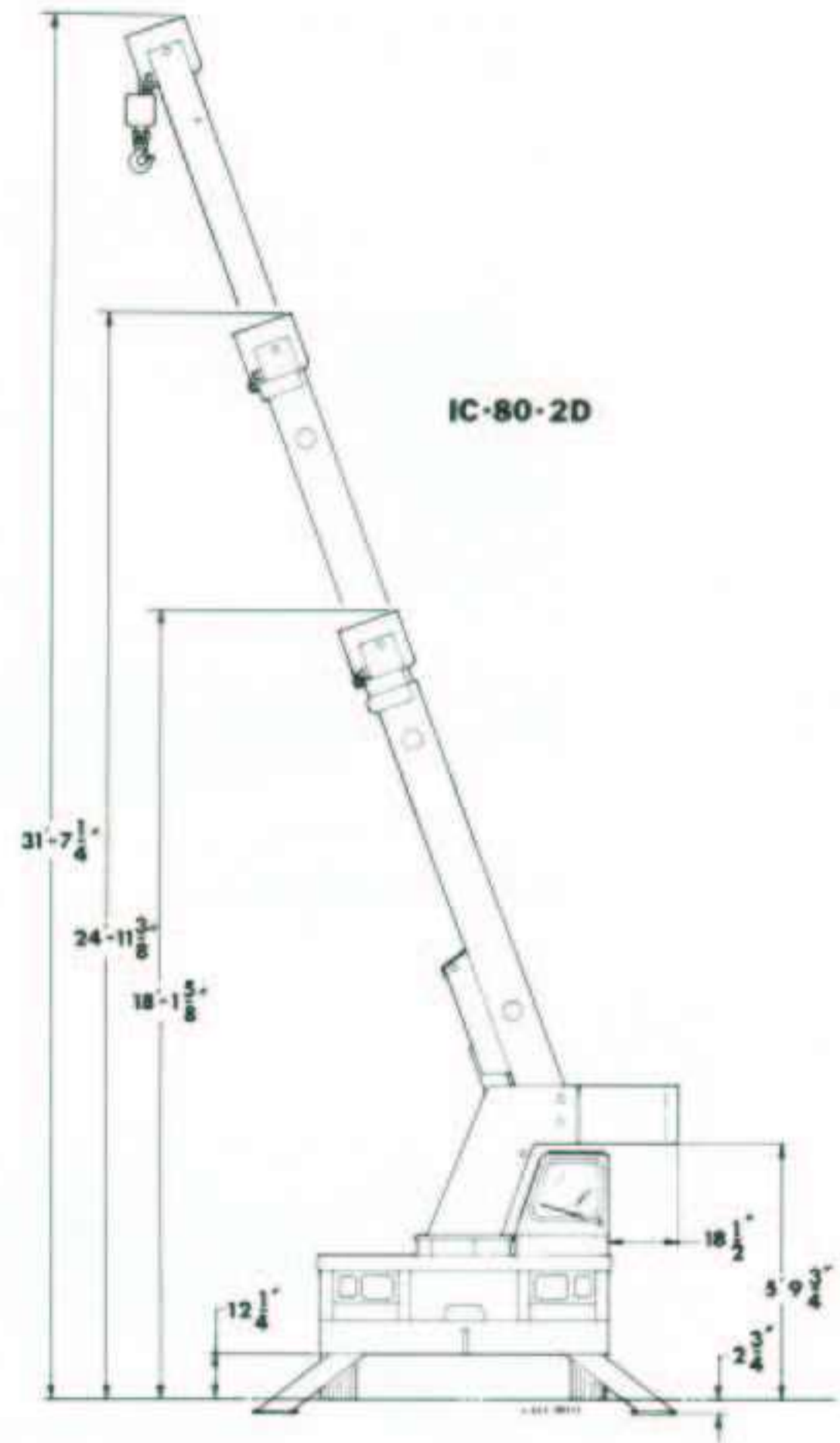
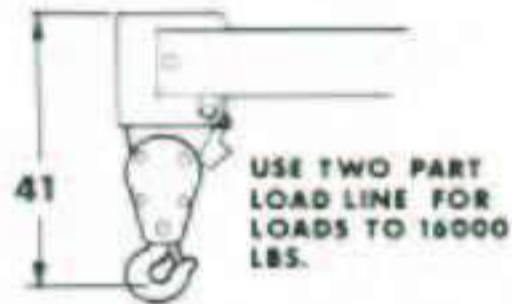
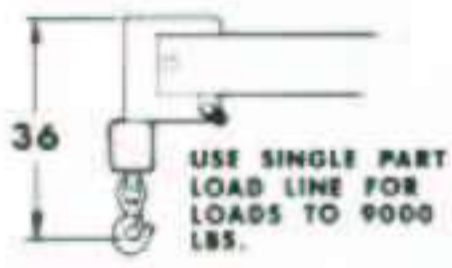

**General:**

	Standard Drive Axle	Optional Drive Steer Axle
<b>Weight:</b> IC-80-1D	14,230 lbs.	14,530 lbs.
IC-80-2D	14,530 lbs.	14,830 lbs.
<b>Travel Speeds (Calculated):</b>		
<b>Gear:</b> First	5.4	3.0
Second	11.0	6.5
Third	20.0	12.0
Fourth	N/A	20.0
<b>Gradeability:</b>	43%	71%
<b>Drawbar Pull:</b>		
<b>Gear</b>	<b>Pounds</b>	<b>Pounds</b>
First	7,050*	11,900*
Second	3,450	5,820*
Third	1,880	3,170
Fourth	N/A	1,880
<b>Turning Radius:</b>		
(C/L of Outside Steering Wheel):	14'8"	10'2"
<b>Aisle Width for 90° Turn:</b>	11'9"	9'9"

\* Wheels will spin before these values are reached.

**Engine:**

	Standard	Optional	Optional	Optional
<b>Make</b>	Continental	John Deere	Perkins	Cummins
<b>Model</b>	TM27	4.239	D4.203	4B3.9
<b>No. of Cyl.</b>	4	4	4	4
<b>Displacement</b>	165 C.I.D.	239 C.I.D.	203 C.I.D.	239 C.I.D.
<b>HP at Governed Speed</b>	64	80	63	76

**Electrical:**

**12 Volt System**

**Lighting Package:**

One Pair Headlights with Hi and Low Beams, Back-up Lights, Integral Tail, Brake and Turn Signals and Front turn Signals

**Instrument Package:**

Fuel, Ammeter, Oil Pressure, Water Temperature, Converter Oil Temperature Gauges and Hourmeter

**Back-Up Alarm**

Provides pulsating sound when transmission is in reverse.

**Transmission:**

**Make:** Borg Warner

**Model:** 72T/T18

**Type:** Reversing Gearbox and Manual Shift Three Speed Gearbox.\*

Equipped with Torque Converter and Transmission Oil Cooler.

<b>Gear Ratio:</b>	<b>Forward</b>	<b>Reverse</b>
First	6.324:1	6.956:1
Second	3.092:1	3.401:1
Third	1.686:1	1.855:1
Fourth*	1:1	1:1

Torque Converter Has Stall Ratio of 2.15:1

\* 4-speed gearbox only available with 4-wheel steer option.

**Axles:**

	Standard	Optional
<b>Drive Axle:</b>		
<b>Make</b>	Rockwell	Hurth
<b>Model</b>	F-146	272A
<b>Gear Ratio</b>	7.2:1	11.98:1
<b>Location</b>	Front	Front
<b>Steering Axle (Non-Driving):</b>		
<b>Make</b>	Rockwell	
<b>Model</b>	FF-931	
<b>Location</b>	Rear	

**Brakes:**

Service - 4-Wheel Drum Type Brakes  
Parking - Band Type Mounted on Transmission

**Tires:**

Standard - 9:00x15, 12-Ply Rating, Highway Tread  
Optional - 10:00x15, 12-Ply Rating, Highway Tread  
Optional - 10:00x15, 14-Ply Rating, Mining & Industrial Tread  
Optional - Grizzley Supersoft XS250x15 Solid Rubber  
Optional - Foam Filling for the Above Pneumatic Tires

**Fuel Tank:**

20 Gallon Capacity

**Outriggers:**

Four Hydraulic Outriggers of Box Beam Construction with Direct-Connected Holding Valves. Independent Controls for Left and Right-Hand Outriggers. Outrigger Pad Dimension 9"x12".

**Cargo Deck:**

62 Square Feet  
12,000 pounds Capacity  
Steps Located on Front Corners

**Hydraulic System:**

Tandem Pump, Direct-Driven by Engine Crankshaft, Rated at 16 and 32.5 GPM at Rated RPM. Hydraulic Oil Tank Capacity of 16 Gallons.

**Steering:**

**Standard:**

Full Hydraulic Orbitrol Unit with Two Double-Acting Hydraulic Cylinders Attached to Rear Axle.

**Optional:**

Full Hydraulic Orbitrol Unit with Two Double-Acting Hydraulic Cylinders Attached to Both Front and Rear Axles.  
Steering Modes Include: Rear Wheel Steer; Round Steer

**Crane:**

<b>Boom Movement:</b>	IC-80-1D	IC-80-2D
Rotation	Continuous	Continuous
Elevation	0° to 70°	0° to 70°
Extension	8'2" to 20'2" (12')	9'6" to 24'
<b>Boom Speeds:</b>		
Rotation	1.7 RPM	1.7 RPM
Elevation	10.0 Seconds	10.0 Seconds
Extension	28.0 Seconds	34.0 Seconds

**Boom Assembly:**

Three-Section Boom Assembly Equipped with Bearing Pads, Double-Acting Hydraulic Cylinders with Direct-Connected Holding Valves and Boom Angle Indicator on Each Side of Boom.

**Boom Rotation:**

Heavy-Duty Ball Bearing Rotation Gear with External Teeth. Rotation is Powered by Hydraulic Motor and Worm Gear Drive.

**Boom Winch:**

Turret-Mounted  
Hydraulic Powered  
Bare Drum Line Pull of 10,000 Pounds  
Winch Line Speed of 110 FPM  
IC-80-1D—90 feet of 9/16" Wire Rope  
IC-80-2D—105 feet of 9/16" Wire Rope  
Downhaul Weight and Swivel Hook

**Anti-Two Block Device:**

Prevents damage to hoist rope and/or crane components from pulling load hook against tip.

**2-Part-Line Sheave Block:**

Single sheave block for two-part-line requirements.

Listed below are brief descriptions of each option available for the IC-80-D Industrial crane.  
Consult the IC-80-D Engineering Spec for additional information on each option.

1. IC-80-1D Industrial Crane with 8'2"-20'2" Boom
2. IC-80-2D Industrial Crane with 9'6"-24' Boom

#### ENGINE OPTIONS:

3. LP Gas Fuel System  
Contains all necessary components for LP gas operations
4. Dual Fuel System  
Contains all necessary components to burn LP gas and gasoline.
- Diesel Engines:**
5. John Deere  
4-cylinder, Model 4239D
6. Perkins  
4-cylinder, Model D4.203
7. Cummins  
4-cylinder, Model 4B3.9
8. Spark Arrester Muffler  
Installed in addition to standard muffler.
9. Catalytic Converter  
Reduces engine emissions, Cummins Diesel only.
10. Engine Heater  
Engine coolant heater installed to circulate warm water through engine, plugs into 120 volt AC.
11. Ether Injection System  
Ether starting aid controlled by switch in operator compartment and injects ether directly into intake manifold, Cummins Diesel only.
12. Engine Shut Down Gauges  
Shuts engine off when high water temperature or low engine oil pressure occurs.

#### FRONT AXLE OPTIONS:

13. No-Spin Differential  
The differential equipped with "No-Spin" feature.
14. Four-Wheel Steering  
Hurth drive/steer axle for four-wheel steering, differential equipped with "No-Spin" feature.

#### TIRE OPTIONS:

15. 10.00 x 15, 12-Ply Rating
16. Solid Rubber Tires
17. 10.00 x 15, 14-Ply Rating, Mining & Industrial Tires

#### FOAM FILLING OF TIRES:

18. 9.00 x 15 Tires
19. 10.00 x 15 Tires

#### SPARE TIRE AND WHEELS:

20. 9.00 x 15
21. 10.00 x 15
22. 10.00 x 15 Mining & Industrial

#### CHASSIS OPTIONS:

23. Accessory Storage Box  
Storage box is 14" deep x 10-1/2" long and 27" wide, located in front carry deck.

24. Auxiliary Winch  
Mounted behind front bumper, hydraulically driven with control in operator's console.
25. Pintle Hook  
Pintle hook mounted on rear frame, 5-ton capacity.
26. Headlight and Taillight Grilles  
Welded steel protective grilles for headlight and taillights.
27. Rearview Mirrors  
One mounted on right-hand deck stake and one mounted on left-hand deck stake.
28. Lifting Rings  
Lifting rings at each corner of carry deck so sling can be attached for lifting crane.

#### OPERATOR COMPARTMENT OPTIONS:

29. Operator Guard  
Tubular steel weldment with heavy expanded steel mesh top section.
30. All-Weather Cab  
Rigid-mounted canopy section and removable hinged door. Includes heater, electric windshield wiper, one sliding glass window in the door and one fold-out window in rear to provide flow-through ventilation. Defroster fan included.
31. Sliding Right-Hand Window  
Window on right-hand side of cab slides open for additional ventilation.
32. Windshield Washer  
Includes reservoir pump and nozzle.
33. Floor Mat  
Vinyl mat with foam backing.
34. Operator Suspension Seat  
Provides additional operator comfort.
35. Noise Reduction Kit  
Includes floor mat, control valve and side panels of foam backed vinyl for noise reduction.

#### ELECTRICAL OPTIONS:

36. Outrigger Warning System  
Two-tone alarm is activated when "outrigger down" controls are operated.
37. Strobe Lights  
Yellow strobe light mounted on each side of turret weight box.
38. Lighted Instrument Gauges  
Instrument gauges equipped with lights for night operations.
39. Amber Rotating Beacons  
Amber rotating beacon mounted on each side of turret weight box.
40. Boom Work Lights  
One work light mounted to boom to light boom tip and one work light mounted to turret to light ground under boom tip.
41. Boom Work Lights and Beacons  
Boom work lights and amber rotating beacons installed.

42. Boom Work Lights and Strobe  
Boom work lights and strobe lights installed.
43. Dome Light  
Interior light installed for units equipped with an all weather cab.

#### HYDRAULIC OPTIONS:

44. Boom Structural Protection System  
Important to understand fully the description of the Boom Structural Protection System described in the IC-80 Engineering Spec. This option is not intended to and will not replace an LMI.
45. Outrigger Control - Individual  
Electric switch used in conjunction with existing two outrigger valve section to select for individual operation of each outrigger.

#### BOOM ATTACHMENTS:

46. Anti-Two Block - Chain & Weight  
Prevents damage to hoist rope and/or crane components from pulling load hook against boom tip. This system uses a suspended weight on the boom tip instead of a trip arm.
47. Boom Extension, 10 Foot  
Boom Stowable, Fiberglass bucket(s) or work platform can be attached to the boom extension tip.
48. Boom Extension, 10 Foot, Offsettable  
Same as item 47, except the boom extension is offsettable to 3 different positions; 0 degree (inline), 15 degree and 30 degree offset.
49. Searcher Hook - "H" Shape  
Swivel hook with spring latch hangs from link under boom tip, 5,000 pound capacity.
50. Searcher Hook - Large  
Swivel hook with spring latch hangs from support structure projecting outward from boom tip, 5,000 pound capacity.
51. Load Moment Indicator - Krueger  
Warns operator of impending overload with audible and visual signals. Prevents overload by stopping boom functions that cause overloads. Readouts for load, boom angle, boom length, and load radius.
52. Load Indicator - Krueger  
Includes 3-sheave load sensor on top of boom and readout box on top of instrument panel.
53. Load Moment Indicator - PAT  
Same as item 51, except manufactured by PAT.
54. Load Indicator - PAT  
Same as item 52, except manufactured by PAT.



# IC-80

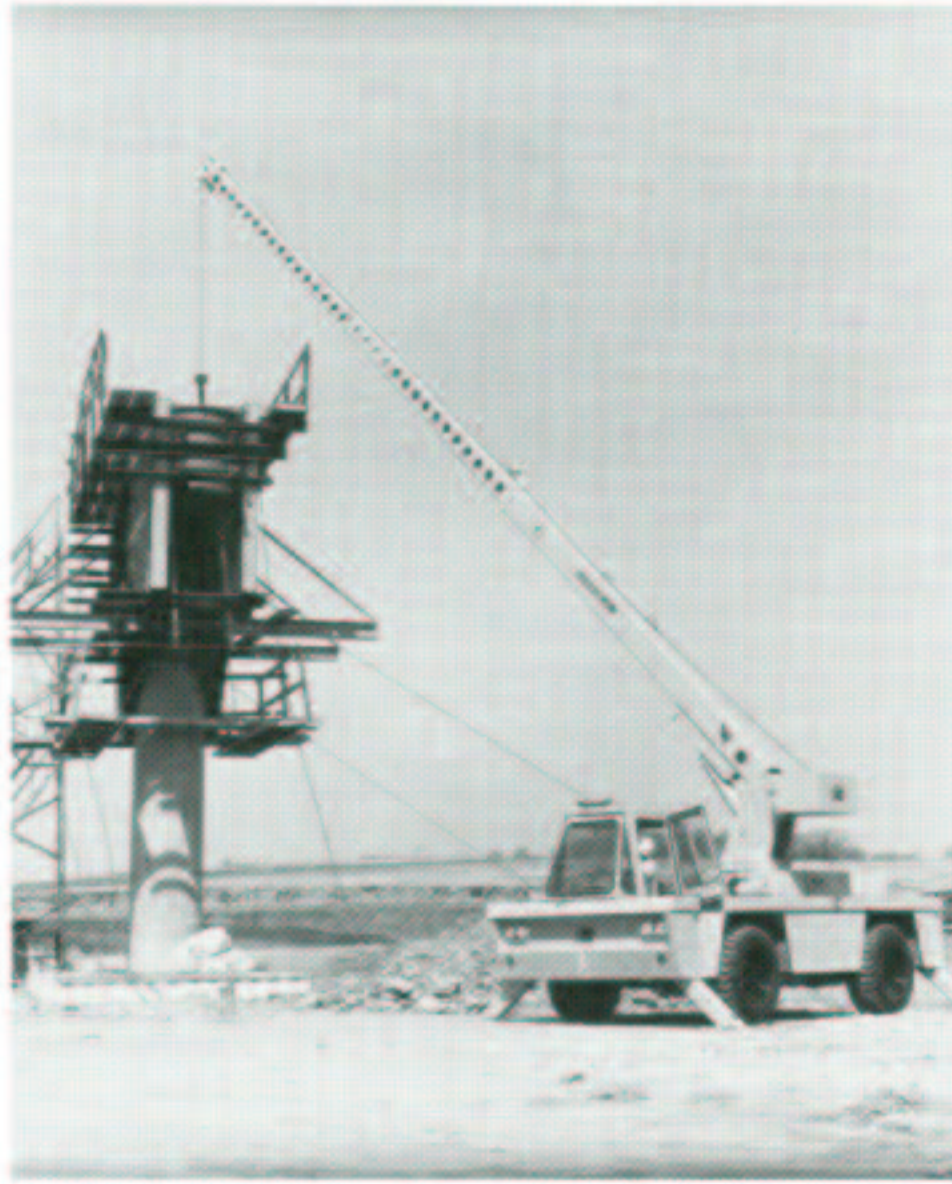

**DMC BRODERSON**  
Manufacturing Corp.

P.O. Box 14770, Lenexa, KS 66285-4770  
(913) 888-0606 • FAX (913) 541-0690